

HL-A-3528H308W-S1-13

Features

- PLCC-2 Package.
- Extremely wide viewing angle
- Suitable for all SMT assembly and solder process
- Available on tape and reel
- Moisture sensitivity level: Level 4
- Package:2000pcs/reel
- RoHS compliant



Description

The White LED which was fabricated using a blue chip and the phosphor

Applications

- Optical indicator
- Indoor display
- Interior automotive lighting
- Backlight for LCD, switch and Symbol, display
- Light pipe application
- General use



ATTENTION
OBSERVE PRECAUTIONS
FOR HANDLING
ELECTROSTATIC
DISCHARGE
SENSITIVE
DEVICES

Package Dimensions

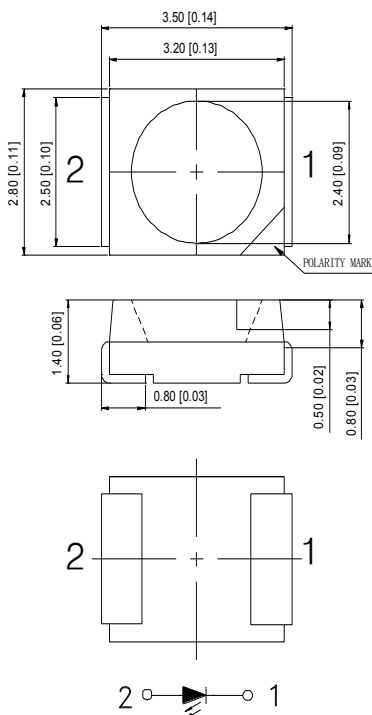

Recommended Soldering

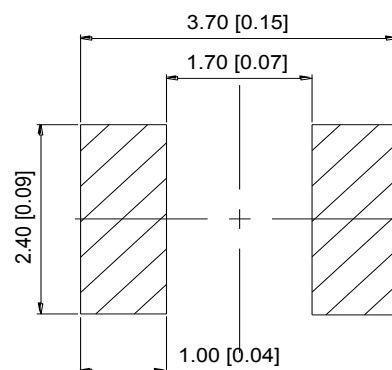

Notes:

1. All dimension units are millimeters.
2. All dimension tolerance is ± 0.15 mm unless otherwise noted.

HL-A-3528H308W-S1-13

Selection Guide

Part No.	Dice	Lens Type	Luminous intensity (mcd) @ 20mA		Luminous flux(lm) @ 20mA		Viewing Angle
			Min.	Max.	Min	Typ	θ1/2
HL-A-3528H308W-S1-13	WHITE (InGaN)	Yellow Diffused	1900	2200	6.0	6.5	120°
			2200	2600			

Note:

1. θ1/2 is the angle from optical centerline where the luminous intensity is 1/2 the optical centerline value.
- 2.the above luminous intensity measurement allowance tolerance ±10%.

Electrical / Optical Characteristics at Ta=25°C

Parameter	Symbol	Min.	Typ.	Max.	Units	Test Conditions
Forward Voltage	V _F	2.8	--	3.4	V	I _F =20mA
Reverse Current	I _R	--	--	10	μA	V _R = 5V
Color Coordinates	X	--	0.32	--	--	I _F =20mA
	Y	--	0.33	--	--	I _F =20mA
Color Temperature	T _c	--	6000	--	K	I _F =20mA
Color Rendering Index	CRI	65	--	--	Ra	I _F =20mA

Absolute Maximum Ratings at Ta=25°C

Parameter	Symbol	Rating	Units
Power Dissipation	P _d	105	mW
DC Forward Current	I _F	30	mA
Peak Forward Current [1]	I _{FP}	100	mA
Reverse Voltage	V _R	5	V
Electrostatic Discharge (HBM)	ESD	1000	V
Operating Temperature	T _{opr}	-40 ~ +85	°C
Storage Temperature	T _{stg}	-40 ~ +100	°C

Note:

- 1.1/10 Duty Cycle, 0.1ms Pulse Width.
- 2.The above forward voltage measurement allowance tolerance ±0.1V
- 3.The above color temperature measurement allowance tolerance ±0.003

HL-A-3528H308W-S1-13

Typical optical characteristics curves

Ambient Temperature VS. Forward Current

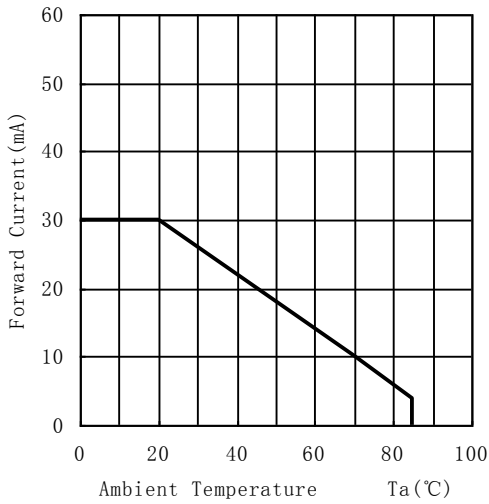

Forward Current VS. Relative Intensity

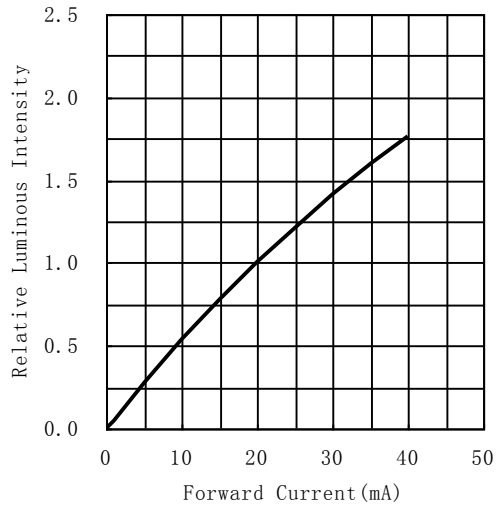

Forward Voltage VS. Forward Current

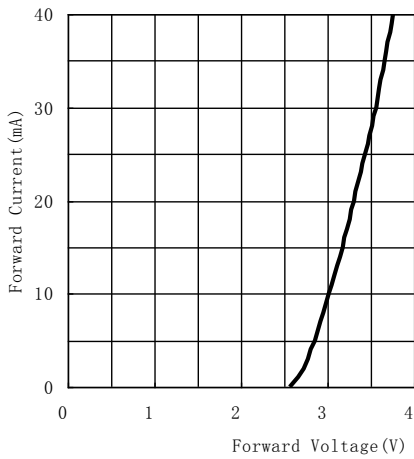

Ambient Temperature VS. Relative Intensity

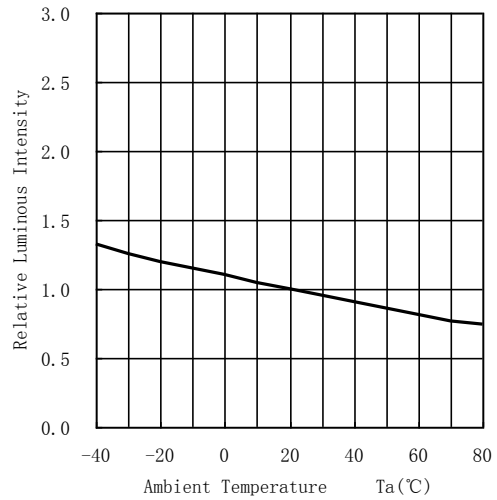

Relative spectral emission

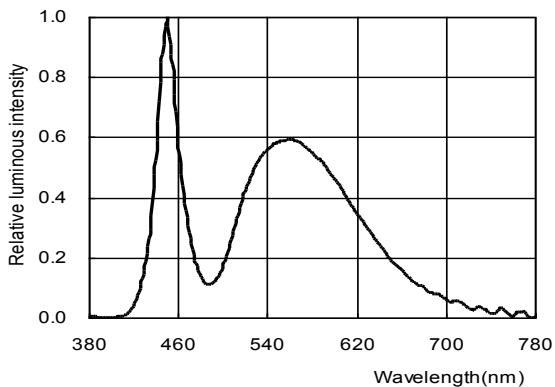
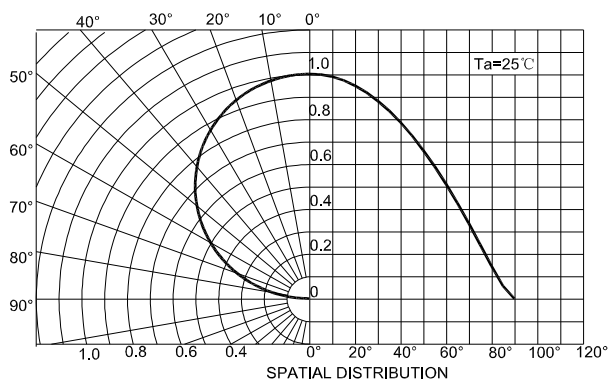

Diagram characteristics of radiation





HL-A-3528H308W-S1-13

CIE Chromaticity Diagram

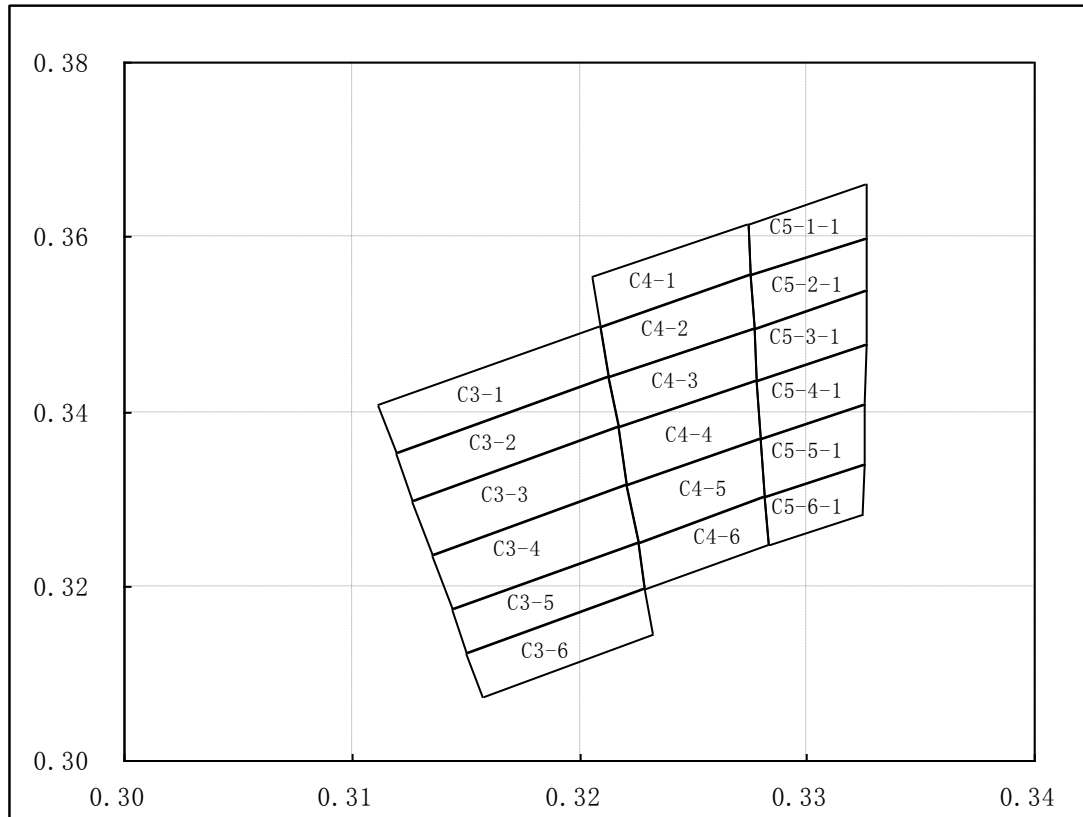

C3-1 6000-6500K				
X	0.3112	0.3209	0.3213	0.3120
Y	0.3408	0.3498	0.3440	0.3354

C3-2 6000-6500K				
X	0.3120	0.3213	0.3217	0.3127
Y	0.3354	0.3440	0.3382	0.3299

C3-3 6000-6500K				
X	0.3127	0.3217	0.3221	0.3136
Y	0.3299	0.3382	0.3317	0.3237

C3-4 6000-6500K				
X	0.3136	0.3221	0.3226	0.3144
Y	0.3237	0.3317	0.3251	0.3174

C3-5 6000-6500K				
X	0.3144	0.3226	0.3229	0.3151
Y	0.3174	0.3251	0.3198	0.3124

C3-6 6000-6500K				
X	0.3151	0.3229	0.3232	0.3157
Y	0.3124	0.3198	0.3145	0.3074

C4-1 5700-6000K				
X	0.3206	0.3274	0.3275	0.3209
Y	0.3554	0.3615	0.3556	0.3498

C4-2 5700-6000K				
X	0.3209	0.3275	0.3277	0.3213
Y	0.3498	0.3556	0.3496	0.3440

C4-3 5700-6000K				
X	0.3213	0.3277	0.3278	0.3217
Y	0.3440	0.3496	0.3436	0.3382

C4-4 5700-6000K				
X	0.3217	0.3278	0.3280	0.3221
Y	0.3382	0.3436	0.3369	0.3317

C4-5 5700-6000K				
X	0.3221	0.3280	0.3281	0.3226
Y	0.3317	0.3369	0.3302	0.3251

C4-6 5700-6000K				
X	0.3226	0.3281	0.3283	0.3229
Y	0.3251	0.3302	0.3247	0.3198

C5-1-1 5500-5700K				
X	0.3274	0.3326	0.3326	0.3275
Y	0.3615	0.3660	0.3599	0.3556

C5-2-1 5500-5700K				
X	0.3275	0.3326	0.3326	0.3277
Y	0.3556	0.3599	0.3538	0.3496

C5-3-1 5500-5700K				
X	0.3277	0.3326	0.3326	0.3278
Y	0.3496	0.3538	0.3477	0.3436

C5-4-1 5500-5700K				
X	0.3278	0.3326	0.3325	0.3280
Y	0.3436	0.3477	0.3409	0.3369

C5-5-1 5500-5700K				
X	0.3280	0.3325	0.3325	0.3281
Y	0.3369	0.3409	0.3340	0.3302

C5-6-1 5500-5700K				
X	0.3281	0.3325	0.3324	0.3283
Y	0.3302	0.3340	0.3283	0.3247



HL-A-3528H308W-S1-13

Reliability Test Items And Conditions

The reliability of products shall be satisfied with items listed below.
Confidence level :90%
LTPD :10%

No.	Items	Ref.Standard	Test Condition	Test Hours/ Cycles	Sample Size	Ac/Re
1	Reflow	JESD22-B106	Temp:260°Cmax T=10 sec	3 times.	22Pcs.	0/1
2	Temperature Cycle	JESD22-A104	100°C±5°C 30 min. ↑↓5 min -40°C±5°C 30 min.	100 Cycles	22Pcs.	0/1
3	Thermal Shock	JESD22-A106	100°C±5°C 5 min. ↑↓ -40°C±5°C 5 min.	100 Cycles	22Pcs.	0/1
4	High Temperature Storage	JESD22-A103	Temp:100°C±5°C	1000Hrs.	22Pcs.	0/1
5	Low Temperature Storage	JESD22-A119	Temp:-40°C±5°C	1000Hrs.	22Pcs.	0/1
6	DC Operating Life	JESD22-A108	Ta=25°C±5°C IF=20mA	1000Hrs.	22Pcs.	0/1
7	High Temperature High Humidity	JESD22-A101	85°C±5°C/ 85%RH IF=5mA	1000Hrs.	22Pcs.	0/1

*The technical information shown in the data sheets are limited to the typical characteristics and circuit examples of the referenced products. It does not constitute the warranting of industrial property nor the granting of any license.



HL-A-3528H308W-S1-13

SMT Reflow Soldering Instructions

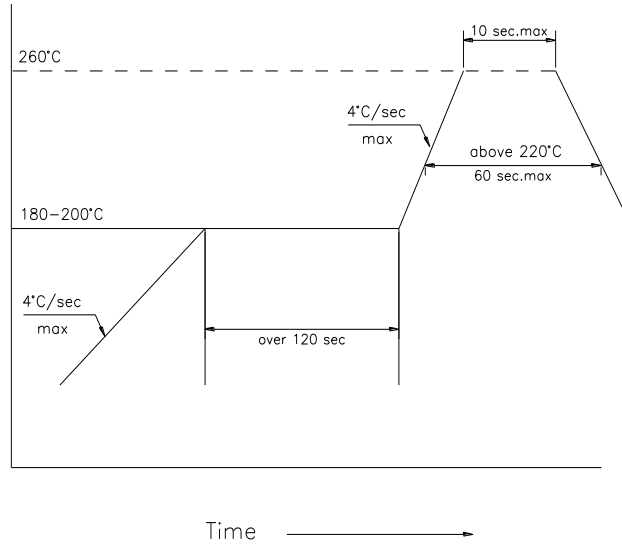

1. Reflow soldering should not be done more than two times
2. When soldering, do not put stress on the LEDs during heating

Soldering iron

1. When hand soldering, the temperature of the iron must be less than 300°C for 3 seconds
2. The hand solder should be done only one time

Repairing

Repair should not be done after the LEDs have been soldered. When repairing is unavoidable, a double-head soldering iron should be used (as below figure). It should be confirmed beforehand whether the characteristics of LEDs will or will not be damaged by repairing.

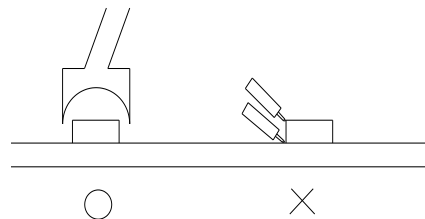

Cautions

The encapsulated material of the LEDs is silicone. Therefore the LEDs have a soft surface on the top of the package. The pressure applied to the top surface will influence the reliability of the LEDs. Precautions should be taken to avoid strong pressure on the encapsulated part. So when using the picking up nozzle, the pressure on the silicone resin should be proper.

HL-A-3528H308W-S1-13

Handling Precautions

Compare to epoxy encapsulant that is hard and brittle, silicone is softer and flexible. Although its characteristic significantly reduces thermal stress, it is more susceptible to damage by external mechanical force. As a result, Special handling precautions need to be observed during assemble using silicone encapsulated LED products, Failure to comply might leads to damage and premature failure of the LED.

1. Handle the component along the side surface by using forceps or appropriate tools

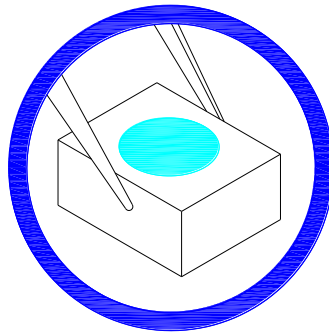

2. Do not directly touch or handle the silicone lens surface. It may damage the internal circuitry

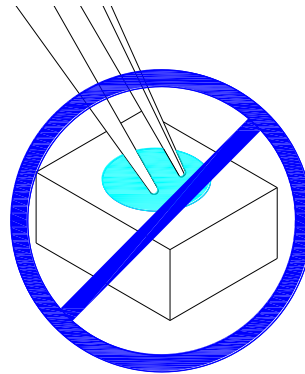
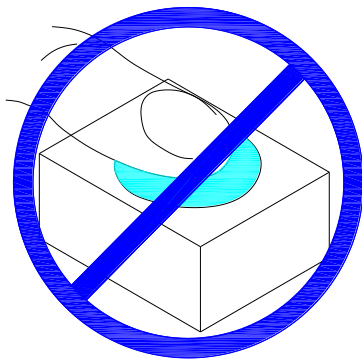

3. Do not stack together assembled PCBs containing LEDs. Impact may scratch the silicone lens or damage

4. Not available in the situation of acidity for PH

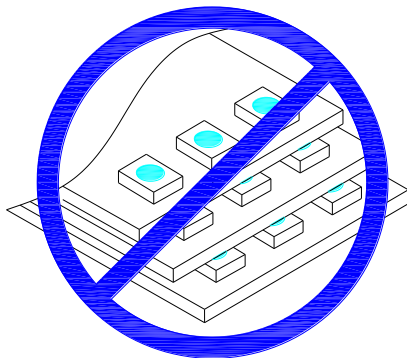

5. LED operating environment and sulfur element composition cannot be over 100PPM in the LED mating usage material.

HL-A-3528H308W-S1-13

Label

IV: Luminous intensity rank
 VF: Forward voltage rank
 X/Y: Coordinate rank
 TC: Color temperature



HONGLITRONIC
鸿利光电

RoHS

Part No: XXXXXXXXXXXXXXXXXXXXXXXX
 IV: VF: X/Y:
 Quantity: TC:
 Sealing date: XXXXXXXXXXXXXXXXXXXX



Tape Specifications (Units : mm)

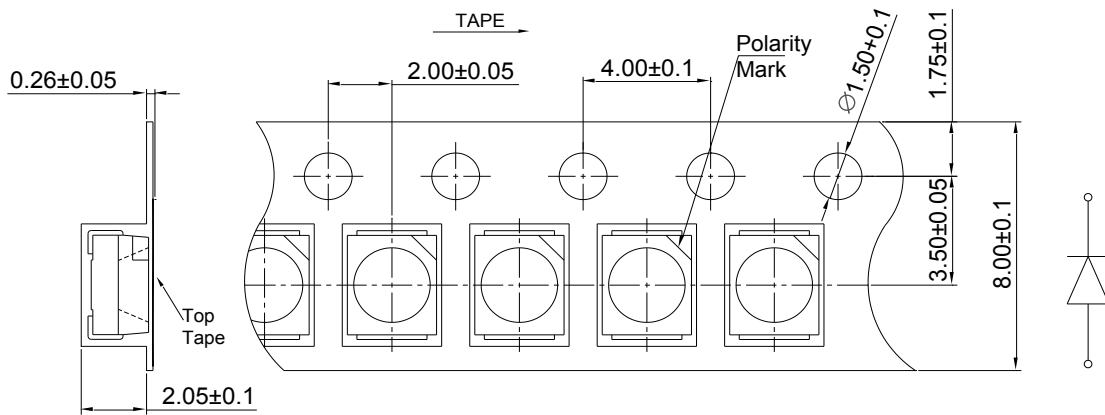

Reel Dimensions

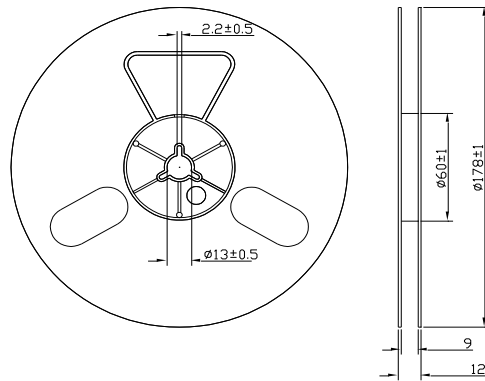

Moisture Resistant Packaging

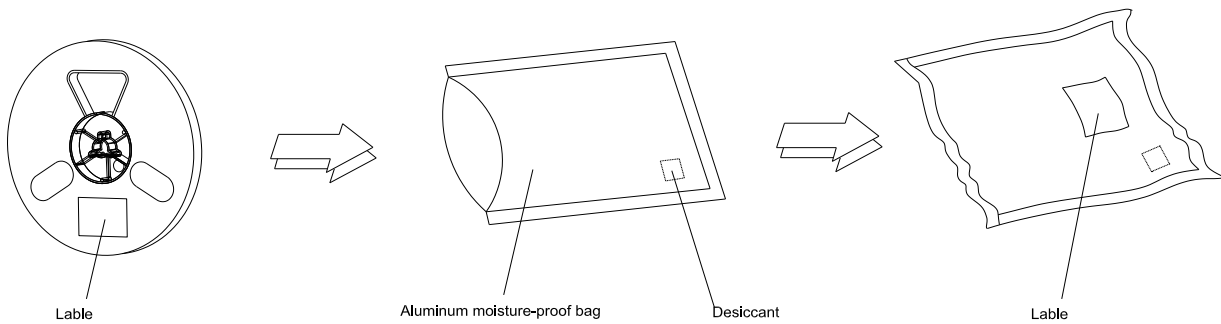

Note: The tolerances unless mentioned is ± 0.1 mm, Unit: mm